

(No Model.)

C. V. WOERD.

LATHE FOR FORMING PIVOTS OF BALANCE WHEEL STAFFS.

No. 372,001.

Patented Oct. 25, 1887.

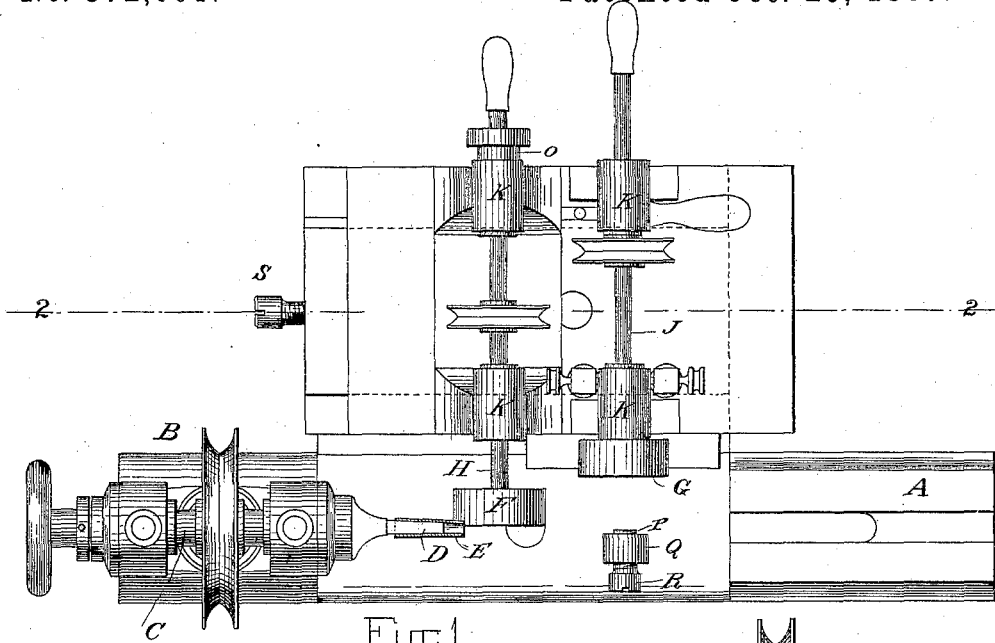

Fig. 1.

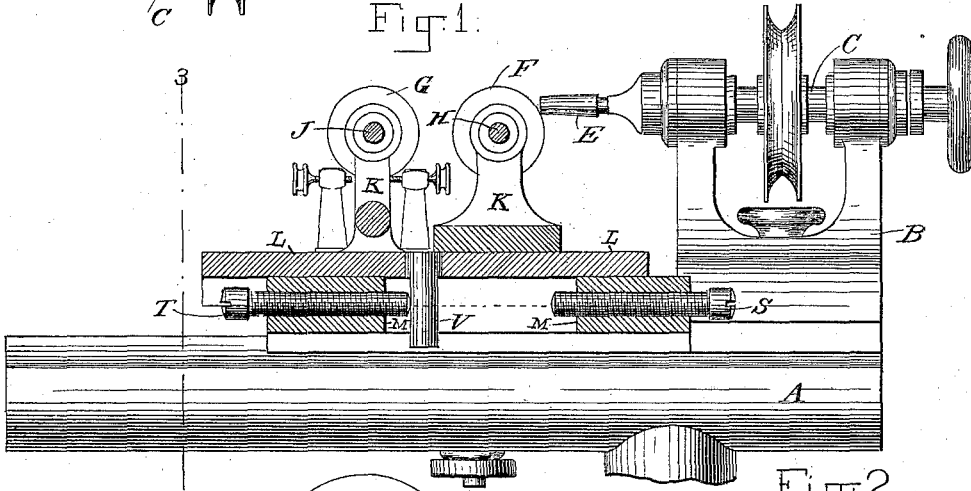

Fig. 2.

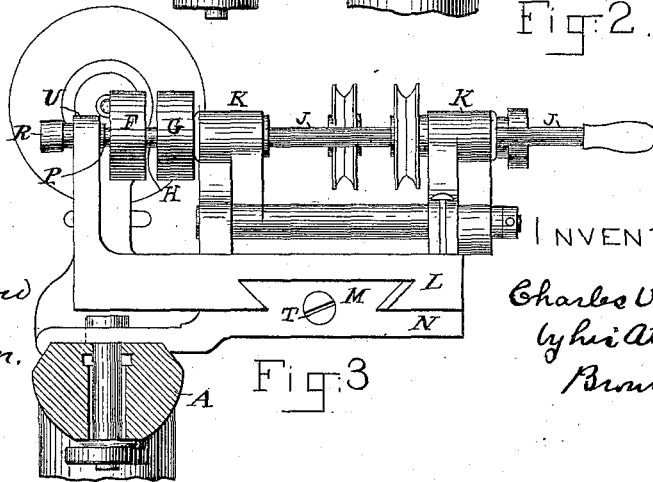

Fig. 3.

WITNESSES

John F. Nelson
Francis M. Brown.

INVENTOR

Charles V. Woerd
by his Attorneys
Brown Bros

UNITED STATES PATENT OFFICE.

CHARLES V. WOERD, OF WALTHAM, MASSACHUSETTS.

LATHE FOR FORMING PIVOTS OF BALANCE-WHEEL STAFFS.

SPECIFICATION forming part of Letters Patent No. 372,001, dated October 25, 1887.

Application filed November 30, 1886. Serial No. 220,263. (No model.)

To all whom it may concern:

Be it known that I, CHARLES V. WOERD, of Waltham, in the county of Middlesex and State of Massachusetts, have invented certain new and useful Improvements in Lathes for Grinding and Otherwise Forming Pivot Ends on Balance-Wheel Staffs of Watch-Movements, of which the following is a full, clear, and exact description.

This invention pertains to the forming of the pivot at the end of the balance-wheel staff of watch-movements, and particularly relates to improvements in lathes for such purpose.

The invention consists, essentially, in the combination, with the center rotating spindle or arbor of the lathe, and to which the balance-wheel staff is secured and axially centered in any suitable manner, of a lap grinding-wheel and a lap polishing, smoothing, or burnishing wheel carried by a common slide which is capable of sliding in a direction parallel with and at one side of the lathe-bed, and for its length of movement to be adjusted to secure the proper placing of the lap polishing-wheel after the lap grinding-wheel has finished its work to the staff, to then operate thereon, and all otherwise substantially as hereinafter described.

In the drawings forming a part of this specification, Figure 1 is a plan view of the lathe. Fig. 2 is a vertical section on line 2 2, Fig. 1, with the lathe turned end for end. Fig. 3 is a cross vertical section on line 3 3, Fig. 2.

In the drawings A represents the lathe bed or shears, and B is the head-stock, supporting a rotating mandrel or arbor, C, and which at its end D is to carry the balance-wheel staff (not shown) to be formed at its end with a pivot. The arbor C is driven in any suitable manner, and its outer end, D, has a sleeve or thimble, E, which fits it tightly, and at its open end receives the balance-wheel staff, which is cemented to secure it, all as well known.

F is the lap grinding-wheel, and G the lap polishing, smoothing, or burnishing wheel. Each wheel F G is carried by a separate rotating shaft, H J, each turning in suitable bearing-blocks, K, of a common horizontal slide, L, having a dovetail-groove fitting over a corresponding horizontal dovetail projection, M, of a table, N, at the rear of the lathe-bed. The

dovetail projection M extends along and in a direction parallel with the length of the lathe-bed A, and both rotating shafts H J, which carry, respectively, the lap grinding and lap polishing or burnishing wheels, as described, are parallel to each other and at right angles to the line of movement of the slide L on table N, which in turn is arranged to be moved along the length of the lathe-bed and to be fastened thereto at any desired point of its length. Each of the rotating shafts H J is capable of being slid lengthwise through its bearings toward and away from the axial line of the lathe-arbor, on which is secured the balance-wheel staff to be ground and smoothed and burnished or polished after being ground, as required to make a pivot end thereto. This slide of the shafts H J in each instance is limited and in the case of the shaft H by the abutment of its collar O against one of its bearing-blocks K, and in the case of the shaft J—the shaft having the polishing lap-wheel G—by its abutment against a jeweled bearing or abutment, P, of a post, Q, carried by the slide L, and which abutment preferably is adjustable, and for such purpose is carried at the end of a screw, R, screwing horizontally into the post Q.

ST are adjustable screw stop-pins in each end of the dovetail projection M for the slide L, and extending in the direction of the length of the movement of the slide, and each at its inner end is in position to make abutment against a vertical pin, U, of the slide L, which pin in the movement of the slide travels in the longitudinal slot V of the dovetail projection M for the slide. By this means the movement of the slide L along the length of the dovetail projection M, secured to the lathe-bed or shears A, as described, may be adjusted at pleasure, thus insuring, after the end of the balance-wheel staff has been ground by the action of the lap grinding-wheel to the general shape of the pivot desired, the then presentation of the lap polishing or burnishing or smoothing-off wheel in a line for being moved forward and toward the balance-wheel staff so ground and so moved forward into the position required to polish and smooth off the surface of the so ground pivot end of the balance-wheel staff, thus finishing the same for use.

Each lap-wheel F G in operation is pressed to its work, and as so pressed each is rotated, the balance-wheel staff at the same time being rotated. The axis of rotation of each wheel
 5 F G is at right angles to the axis of rotation of the lathe-arbor and the balance-wheel staff.

Having thus described my invention, what I claim, and desire to secure by Letters Patent, is—

10 1. In a lathe of otherwise suitable construction for grinding and finishing pivot ends to balance-wheel staffs of watch-movements, separate rotating and lengthwise-moving lap
 15 grinding and finishing wheels, F G, carried in common by a slide, L, having an adjustable limited lengthwise movement in the direction of the length of the lathe-bed, substantially as described, for the purpose specified.

20 2. In a lathe of otherwise suitable construction for grinding and finishing pivot ends to balance-wheel staffs of watch-movements, separate rotating and lengthwise-moving lap
 grinding and finishing wheels, F G, carried in common by a slide, L, of a guideway, M,

lengthwise adjustable on the lathe bed or 25 shears, in combination with adjustable stop-pins S T, to limit the lengthwise movement of slide L, substantially as described, for the purpose specified.

3. In a lathe of otherwise suitable construction 30 for grinding and finishing pivot ends to balance-wheel staffs of watch-movements, separate rotating and lengthwise-moving lap grinding and finishing wheels, F G, carried in common by a slide, L, having an adjustable
 35 lengthwise movement in the direction of the length of the lathe-bed, in combination with an adjustable stop, P, for the transverse slide of the lap finishing-wheel G, substantially as described, for the purpose specified. 40

In testimony whereof I have hereunto set my hand in the presence of two subscribing witnesses.

CHAS. V. WOERD.

Witnesses:

R. M. STARK,
 THOS. B. EATON.